

ISL85033CRSHEVAL1Z Wide VIN Current Sharing Standard Buck Regulator With 6A Output Current

Description

The ISL85033CRSHEVAL1Z kit is intended for use by individuals with requirements for Point-of-Load applications sourcing from 4.5V to 28V. The ISL85033CRSHEVAL1Z evaluation board is used to demonstrate the performance of the ISL85033 wide VIN standard buck regulator with 6A output current.

The ISL85033 is offered in a 4mmx4mm 28 Ld TQFN package with 1mm maximum height. The complete converter occupies 6.25cm² area.

Key Features

- Wide Input Voltage Range from 4.5V to 28V
- Adjustable Output Voltage with Continuous Output Current up to 6A
- Current Mode Control
- Adjustable Switching Frequency from 300kHz to 2MHz
- Power-Good Detection
- External Soft-start Time
- Overcurrent and Hiccup Mode Short Circuit Protection, Thermal Overload Protection, UVLO
- Boot Undervoltage Detection
- Channels are Out-of-phase, Reducing Voltage Ripple and Component Size

Recommended Equipment

The following materials are recommended to perform testing:

- 0V to 30V Power Supply with at least 7A source current capability or 5V battery
- Electronic Loads capable of sinking current up to 7A
- Digital Multimeters (DMMs)
- 100MHz quad-trace oscilloscope
- Signal generator

Quick Setup Guide

1. Ensure that the circuit is correctly connected to the supply and loads prior to applying any power.
2. Connect the bias supply to VIN1, the plus terminal to VIN1 and the negative return to GND2.
3. Verify that the position is ON for S1 and S2.
4. Turn on the power supply.
5. Verify the output voltage is 5V for V_{OUT}.

Evaluating the Other Output Voltage

The ISL85033CRSHEVAL1Z kit output is preset to 5V; however, output voltages can be adjusted from 0.8V to 5V. The output voltage programming resistor, R3, will depend on the desired output voltage of the regulator. The value for the feedback resistor is typically between 0Ω and 42.3kΩ as shown in Equation 1.

$$R3 = R2 \left(\frac{V_{OUT}}{V_{FB}} - 1 \right) \quad (EQ. 1)$$

If the output voltage desired is 0.8V, then R3 is shorted. The value for R2 is typically between 1k and 10k. Please note that if V_{OUT} is less than 2.5V, the switching frequency and compensation must be changed for 300kHz operation due to minimum on-time limitation. Please refer to the data sheet for further information ([FN6676](#)).

Frequency Control

ISL85033 has an FS pin that controls the frequency of operation. Programmable frequency allows for optimization between efficiency and external component size. Default switching frequency is 500kHz when FS is tied to VCC (R9 = 0). By removing R9 and connecting R10 to GND, the switching frequency could be changed from 300kHz (R10 = 383k) to 2MHz (R10 = 40.2k). Please refer to the data sheet ([FN6676](#)) for calculating the value of R10. Do not leave this pin floating.

Disabling/enabling Function

The ISL85033 evaluation board contains S1, S2 switches that need to be tied together in current sharing in order to enable or disable both of the channels, thus allowing low quiescent current state. Table 1 details this function.

TABLE 1. SWITCH SETTINGS

S1	S2	ON/OFF CONTROL
ON	ON	Enable V _{OUT}
OFF	OFF	Disable V _{OUT}

SYNC Control

The ISL85033 evaluation board has an SI pin that allows external synchronization frequency to be applied. Default board configuration has R18 = 0 to GND, which defaults to the internal selected switching frequency. Removing R18 allows the synchronization to be external between 600kHz to 4MHz. Do not leave this pin floating.

ISL85033CRSHEVAL1Z Schematic

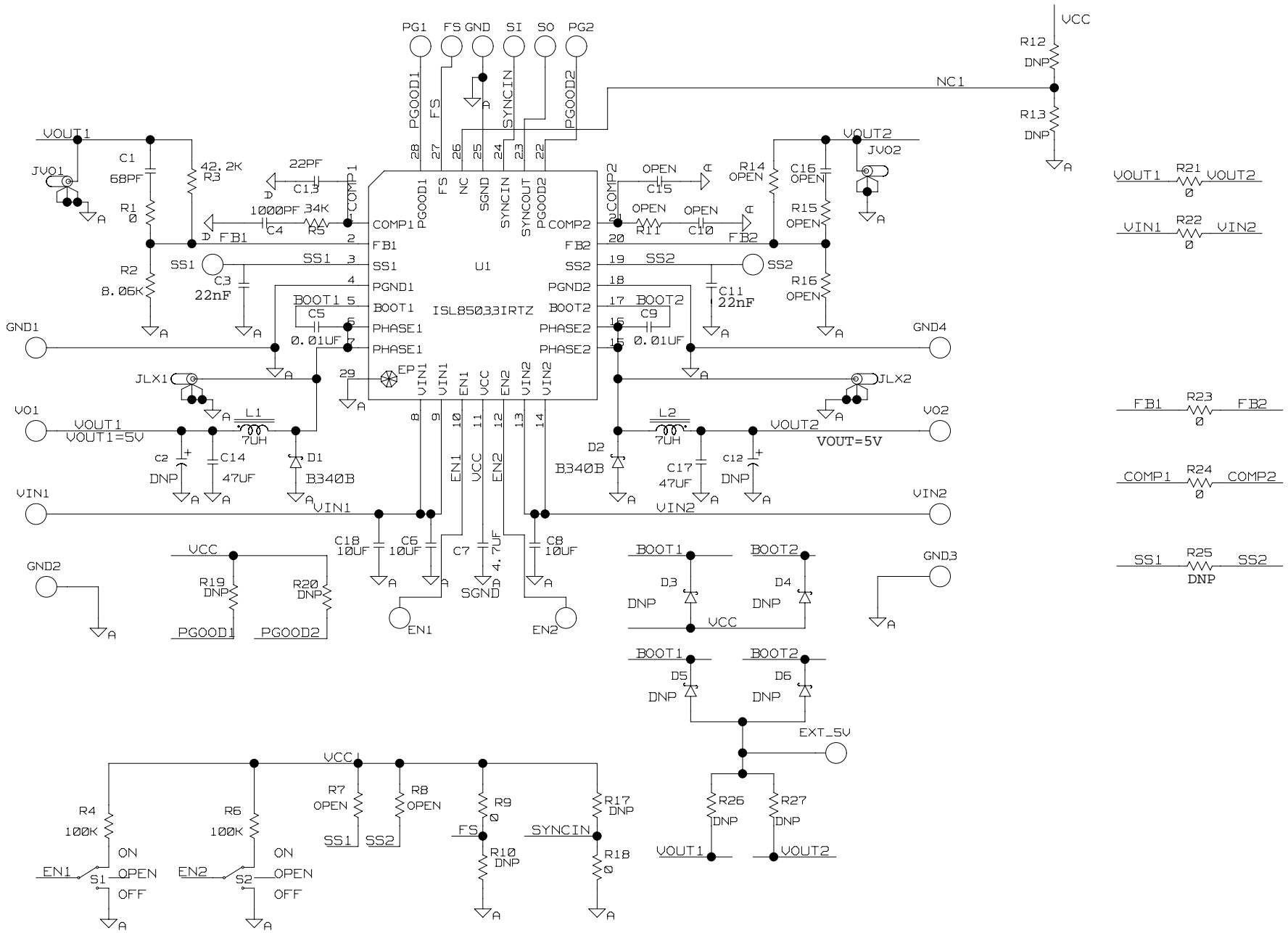

Application Note 1605

TABLE 2. BILL OF MATERIALS

PART NUMBER	QTY	UNITS	REFERENCE DESIGNATOR	DESCRIPTION	MANUFACTURER	MANUFACTURER PART
ISL85033EVAL1ZREVBPCB	1	ea	SEE LABEL-RENAME BOARD	PWB-PCB, ISL85033EVAL1Z, REVB, ROHS	TBD	ISL85033EVAL1ZREVBPCB
EEE-FK1V101P-T	0	ea	DNP (C2,C12)	CAP, SMD, 8X10.2, 100µF, 35V, 20%, AL.EL., ROHS	PANASONIC	EEE-FK1V101P
GMK325BJ106KN-T	2	ea	C6,C8	CAP, SMD, 1210, 10µF, 35V, 10%, X5R, ROHS	TAIYO YUDEN	GMK325BJ106KN-T
H1044-00220-50V5-T	1	ea	C13	CAP, SMD, 0402, 22pF, 50V, 5%, NPO, ROHS	MURATA	GRM36COG220J050AQ
					PANASONIC	ECU-E1H220JCQ
					SAMSUNG	CL05C220JBNC
H1044-00680-50V10-T	1	ea	C1	CAP, SMD, 0402, 68pf, 50V, 10%, X7R, ROHS	MURATA	GRM36COG680K050AQ
					PANASONIC	ECJ-OEC1H680J
					VENKEL	C0402COG500-680KNE
H1045-00102-50V5-T	1	ea	C4	CAP, SMD, 0603, 1000pF, 50V, 5%, COG, ROHS	MURATA	GRM1885C1H102JA01D
					VENKEL	C0603COG500-102JNE
					PANASONIC	ECJ-1VC1H102J
					TDK	C1608C0G1H102J
					AVX	06035A102JAT2A
					KEMET	C0603C102J5GACTU
H1045-00103-50V10-T	2	ea	C5, C9	CAP, SMD, 0603, 0.01µF, 50V, 10%, X7R, ROHS	MURATA	GRM39X7R103K050
					AVX	06035C103KAT2A
					VENKEL	C0603X74500-103KNE
H1045-00473-50V10-T	1	ea	C3, C11	CAP, SMD, 0603, 22nF, 50V, 10%, X7R, ROHS	PANASONIC	ECJ-1VB1H473K
H1045-00475-6R3V10-T	1	ea	C7	CAP, SMD, 0603, 4.7µF, 6.3V, 10%, X5R, ROHS	VENKEL	C0603X5R6R3-475KNE
					TDK	C1608X5R0J475K
					PANASONIC	ECJ-1VB0J475K
					MURATA	GRM188R60J475KE19D
					KEMET	C0603C475K9PACTU
H1045-00475-6R3V10-T	1	ea	C7	CAP, SMD, 0603, 4.7µF, 6.3V, 10%, X5R, ROHS	TAIYO YUDEN	JMK107BJ475KA-T
H1045-DNP	0	ea	C10, C15, C16	CAP, SMD, 0603, DNP-PLACE HOLDER, ROHS		
H1082-00106-50V10-T	1	ea	C18	CAP, SMD, 1210, 10µF, 50V, 10%, X5R, ROHS	TAIYO YUDEN	UMK325BJ106KM-T

Application Note 1605

TABLE 2. BILL OF MATERIALS (Continued)

PART NUMBER	QTY	UNITS	REFERENCE DESIGNATOR	DESCRIPTION	MANUFACTURER	MANUFACTURER PART
H1082-00476-16V20-T	2	ea	C14, C17	CAP, SMD, 1210, 47µF, 16V, 20%, X5R, ROHS	TDK	C3225X5R1C476M
					PANASONIC	ECJ-4YB1C476M
					MURATA	GRM32ER61C476ME15L
					TAIYO YUDEN	EMK325BJ476MM-T
					KEMET	C1210C476M4PACTU
					VENKEL	C1210X5R160-476MNE
SQL004	2	ea	L1, L2	COIL-PWR INDUCTOR, SMD, 10mm, 7µH, 25%, 4.8A, ROHS	FALCO	SQL004
131-4353-00	4	ea	JLX1, JLX2, JV01, JV02	CONN-SCOPE PROBE TEST PT, COMPACT, PCB MNT, ROHS	TEKTRONIX	131-4353-00
1514-2	8	ea	V01, V02, GND1-GND4, VIN1, VIN2	CONN-TURRET, TERMINAL POST, TH, ROHS	KEYSTONE	1514-2
5002	11	ea	a) FS, SI, SO, EN1, EN2, GND, PG1, PG2	CONN-MINI TEST POINT, VERTICAL, WHITE, ROHS	KEYSTONE	5002
5002	0	ea	b) SS1, SS2, EXT_5V	CONN-MINI TEST POINT, VERTICAL, WHITE, ROHS	KEYSTONE	5002
B340B-13-F-T	2	ea	D1, D2	DIODE-SCHOTTKY, SMD, SMB, 2P, 40V, 3A, ROHS	DIODES INC.	B340B-13-F
ISL85033IRTZ	1	ea	U1	IC-3A DUAL STD REGULATOR, 28P, TQFN, 4x4, ROHS	INTERSIL	ISL85033IRTZ
H2505-DNP	0	ea	R10, R17, R19, R20, R26, R27	RESISTOR, SMD, 0603, 0.1%, MF, DNP-PLACE HOLDER		
H2510-04222-1/16W1-T	1	ea	R3	RES,SMD, 0402, 42.2k, 1/16W, 1%, TF, ROHS	PANASONIC	ERJ-2RKF4222X
					VENKEL	CR0402-16W-4222FT
H2510-08061-1/16W1-T	1	ea	R2	RES, SMD, 0402, 8.06k, 1/16W, 1%, TF, ROHS	VENKEL	CR0402-16W-8061FT
					PANASONIC	ERJ-2RKF8061X
					ROHM	MCR01MZPF8061
					YAGEO	RC0402FR-078K06L
					VISHAY/DALE	CRCW04028K06FKED
H2510-DNP	0	ea	R7, R8, R14, R16	RES, SMD, 0402, DNP, DNP, DNP, TF, ROHS		
H2511-00R00-1/10W-T	1	ea	R25	RES, SMD, 0603, DNP	VENKEL	CR0603-10W-000T
					ROHM	MCR03EZPJ000

Application Note 1605

TABLE 2. BILL OF MATERIALS (Continued)

PART NUMBER	QTY	UNITS	REFERENCE DESIGNATOR	DESCRIPTION	MANUFACTURER	MANUFACTURER PART
H2511-00R00-1/10W-T	6	ea	R1, R9, R18, R23, R24	RES, SMD, 0603, 0Ω, 1/10W, TF, ROHS	VENKEL	CR0603-10W-000T
					ROHM	MCR03EZPJ000
					PANASONIC	ERJ-3GEY0R00V
					YAGEO	RC0603JR-070RL
					VISHAY/DALE	CRCW06030000Z0EA
H2511-01004-1/10W1-T	2	ea	R4, R6	RES, SMD, 0603, 1M, 1/10W, 1%, TF, ROHS	PANASONIC	ERJ-3EKF1004V
					VENKEL	CR0603-10W-1004FT
					YAGEO	RC0603FR-071ML
					ROHM	MCR03EZPFX1004
					KOA	RK73H1JTTD1004F
					VISHAY/DALE	CRCW06031M00FKEA
H2511-03402-1/10W1-T	1	ea	R5	RES, SMD, 0603, 34k, 1/10W, 1%, TF, ROHS	VENKEL	CR0603-10W-3402FT
					PANASONIC	ERJ-3EKF3402V
					YAGEO	RC0603FR-0734KL
					VISHAY/DALE	CRCW060334K0FKEA
					ROHM	MCR03EZPFX3402
H2511-DNP	0	ea	R11, R12, R13, R15	RES, SMD, 0603, DNP-PLACE HOLDER, ROHS		
H2514-00R00-1/4W-T	2	ea	R21, R22	RES, SMD, 1210, 0Ω, 1/4W, TF, ROHS	VENKEL	CR1210-4W-000
GT13MCBE	2	ea	S1, S2	SWITCH-TOGGLE, THRU-HOLE, 5PIN, SPDT, 3POS, ON-OFF-ON, ROHS	C&K COMPONENTS	GT13MCBE
SJ-5003-BLACK	4	ea	Bottom four corners	BUMPONS, 0.44" W x 0.20" H, DOMETOP, BLACK	3M	SJ-5003SPBL
5X8-STATIC-BAG	1	ea	Place assy in bag	BAG, STATIC, 5X8, ZIPLOC, ROHS	INTERSIL	212403-013
DNP	0	ea	D3-D6	DO NOT POPULATE OR PURCHASE		
LABEL-RENAME BOARD	1	ea	RENAME PCB TO: ISL85033CRSHEVAL1Z	LABEL, TO RENAME BOARD	INTERSIL	LABEL-RENAME BOARD
LABEL-SERIAL NUMBER	1	ea		LABEL, FOR SERIAL NUMBER AND BOM REV #		

ISL85033CRSHEVAL1Z Board Layout

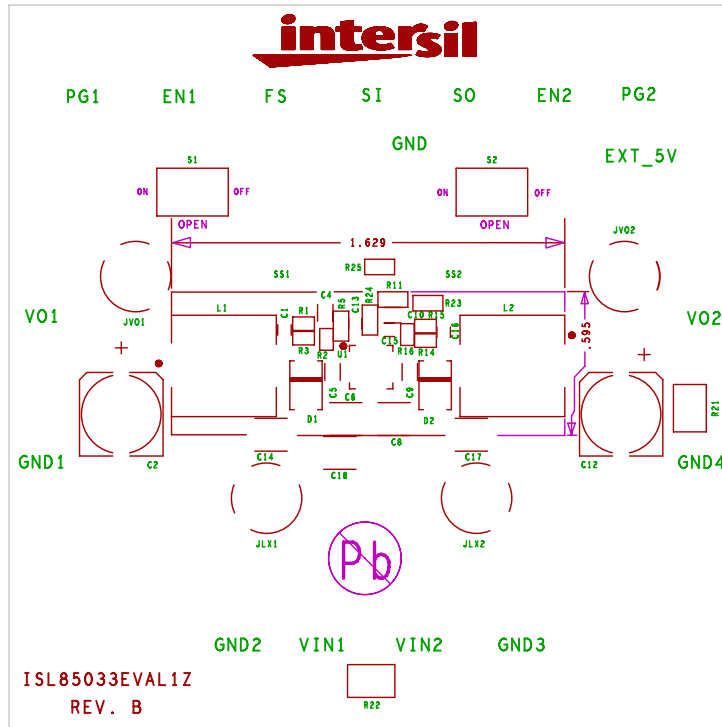

FIGURE 1. TOP LAYER COMPONENTS

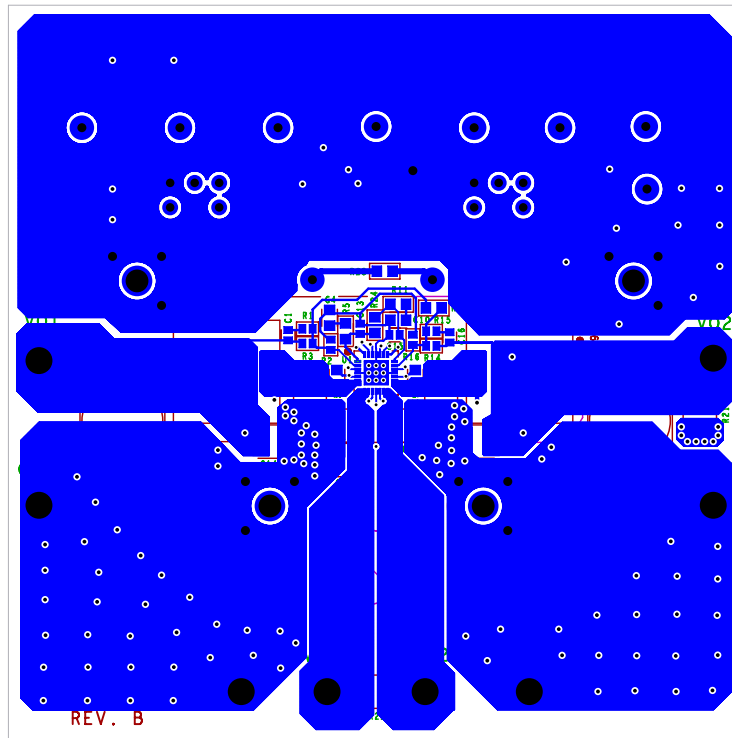

FIGURE 2. TOP LAYER ETCH

ISL85033CRSHEVAL1Z Board Layout (Continued)

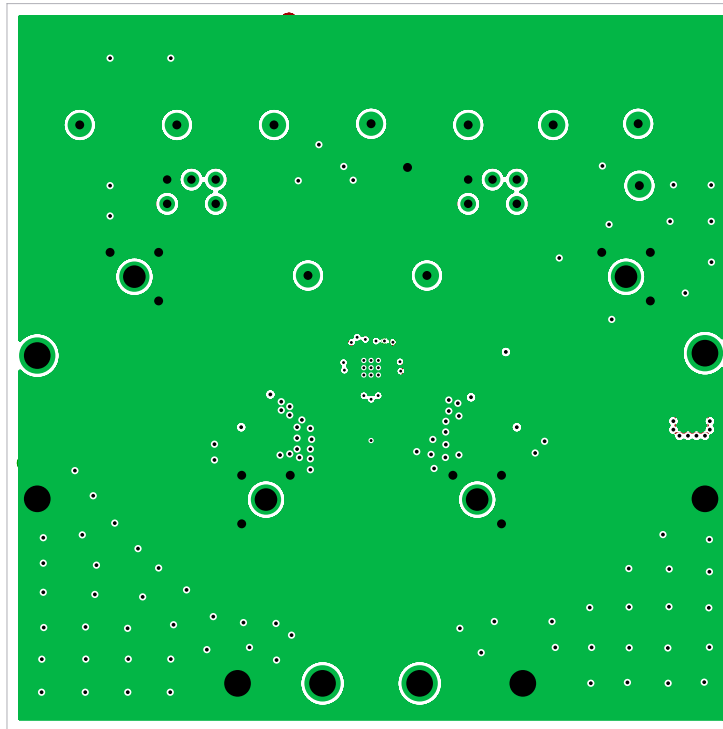

FIGURE 3. SECOND LAYER ETCH

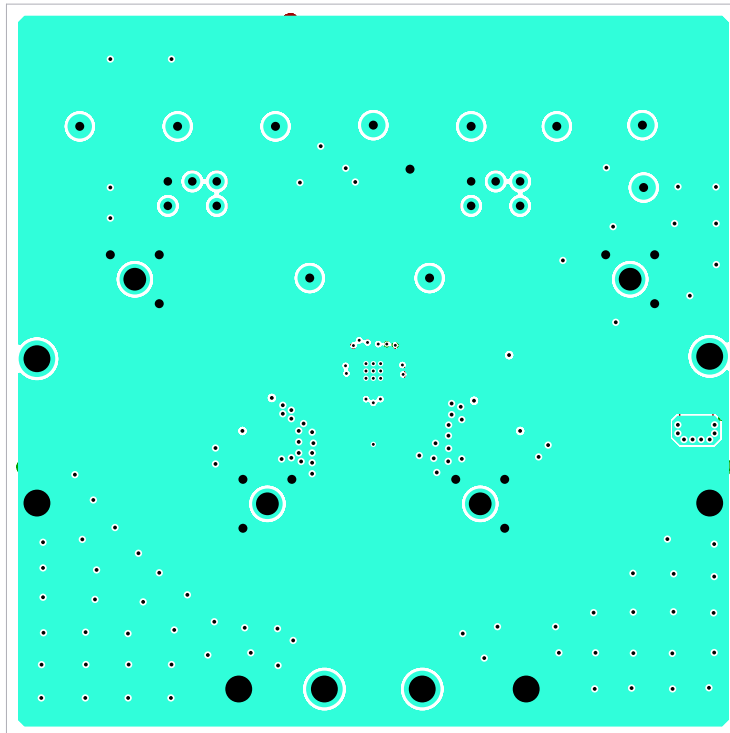

FIGURE 4. THIRD LAYER ETCH

ISL85033CRSHEVAL1Z Board Layout (Continued)

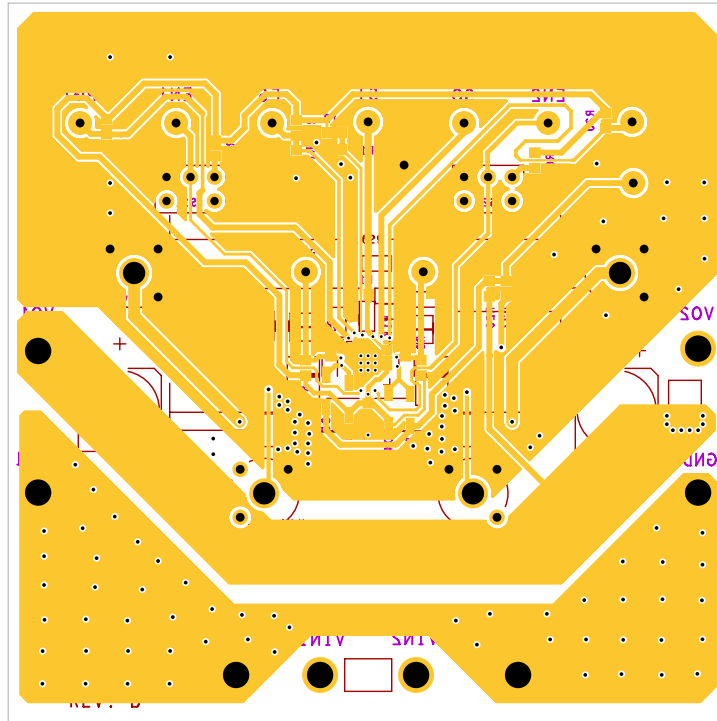

FIGURE 5. BOTTOM LAYER ETCH

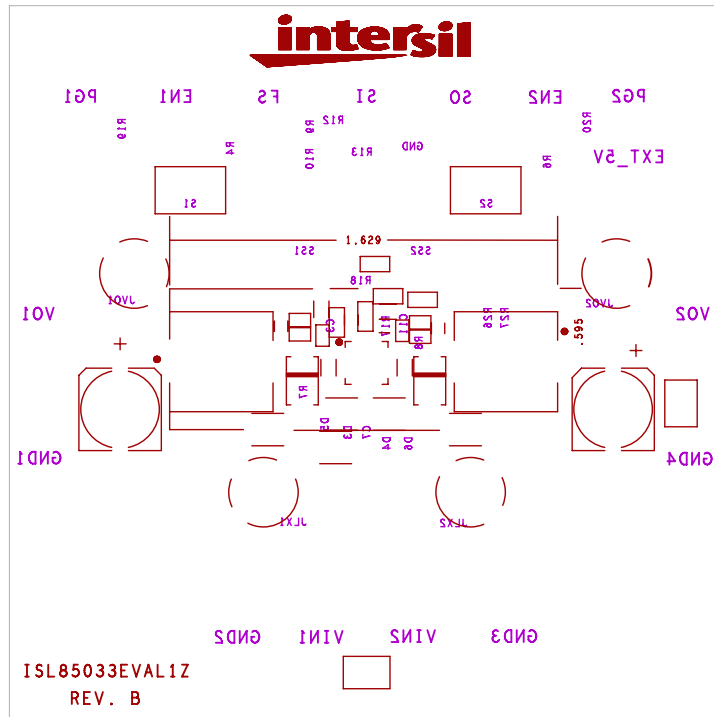

FIGURE 6. BOTTOM LAYER COMPONENTS

Intersil Corporation reserves the right to make changes in circuit design, software and/or specifications at any time without notice. Accordingly, the reader is cautioned to verify that the Application Note or Technical Brief is current before proceeding.

For information regarding Intersil Corporation and its products, see www.intersil.com